

V-Series S2E/S2T

Small, Powerful Modular Style Programmable Controllers

Toshiba's S2E/S2T controllers are small, modular type programmable controllers suitable for simple relay replacement all the way to complex control applications. The S2E/S2T are 3rd generation T2 Series CPUs used with V-Series racks, I/O, and power supplies. The S2E/S2T provides a functional, economical, and compact solution to a wide range of applications in automotive, machine control, and process control systems.

S2E

Local I/O	2048 Points
Program	32 Ksteps (Includes Comments)
Speed	0.11 μ s/contact 0.65 μ s/transfer 17.3 μ s/floating point add.
Station Bus	No



S2T

Local I/O	2048 Points
Program	32 Ksteps (Includes Comments)
Speed	0.09 μ s/contact 0.54 μ s/transfer 12.1 μ s/floating point add.
Station Bus	Yes

KEY FEATURES

High Speed Processing

The S2E/S2T controllers excel at applications where high speed processing is required.

	S2E	S2T
Contact Instruction:	0.11 μ S	0.09 μ S
Coil Instruction:	0.22 μ S	0.18 μ S
Transfer Instruction:	0.65 μ S	0.54 μ S
16-bit Addition:	1.08 μ S	0.90 μ S

T-Series Compatible

The programming tool for the S2E/S2T is the T-PDS MS Windows based programming software. Any T-Series program can be loaded and run without any program conversion. Any HMI, OIS, or Scada software used with the T-Series is also compatible.

Comment Storage in CPU

The device/register tag and comment can be stored in the S2E/S2T CPU memory. Tags and comments can be viewed in the on-line mode without access to the original program (tags and comments are normally stored on the computer hard disk that created the program). Debugging, trouble shooting and editing is much simpler at the installation if tags and comments are viewable.

Built-in Serial Communications

The S2E/S2T have an RS485 serial communications port on the CPU module. One of two modes is selectable; computer link mode or free ASCII mode. In the computer link mode a higher level controller, MMI/OIS, SCADA software can connect to the CPU. T-PDS programming software can also connect in this mode for remote programming. In the free ASCII mode the CPU can communicate with devices that have a simple ASCII protocol such as T1 PLCs, Toshiba ASDs, bar code readers, etc.

Large Program Memory

Both S2E & S2T CPUs have 32k steps of program memory (64k step S2T version is also available). This allows program creation without any consideration for memory constraints. Non-volatile flash memory is used for permanent program storage. Important register values can also be stored in flash memory.

Debug Support Functions

The S2E/S2T offer many useful on-line debug functions such as input force, coil force, data set, status latch & sample trace.

Status Latch: This function collects (latches) the on/off state of devices or values in registers when a user specified condition is initiated.

Sample Trace: This function collects (records) the on/off state of devices or values in registers over a user specified interval when a user specified condition is initiated. The collected data can be viewed as a historical trend graph or exported as a *.csv file.

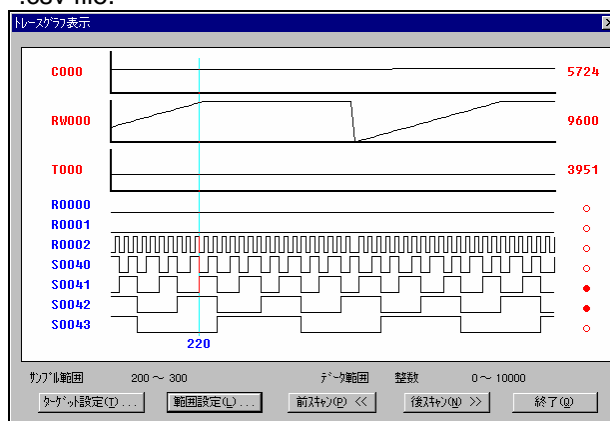

Sample Trace Screen

Process I/O

Fast 8 channel analog input modules and 4 channel analog output modules solve many difficult process applications. One analog output module has an output hold function for safety during a down condition

Multiple Programming Languages

Both LD (ladder diagram) and SFC (sequential function chart) programming are available. Up 11 lines of ladder can be included in each SFC action block. Using SFC makes programs easier to understand and it makes the system easier to troubleshoot.

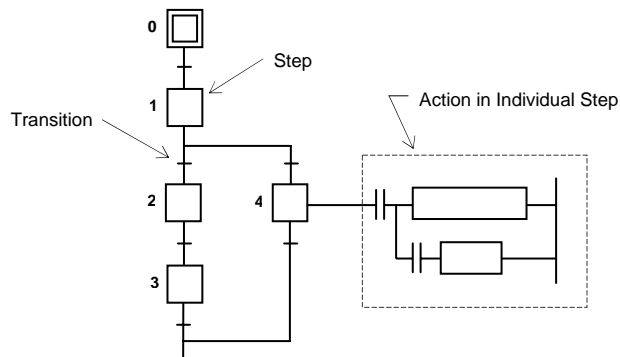

SYSTEM CONFIGURATION

The S2E/S2T configurations are available from a very simple 3 I/O slot system to a to a large local system with several networking options.

Basic System:

The simplest configuration consists of a power supply, S2E/S2T CPU, and any combination of 3 I/O or network modules.

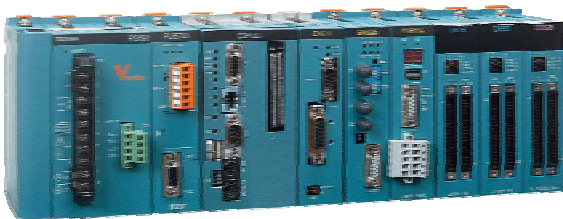

Integrated System:

A fully integrated system consists of a power supply, an S2T CPU, a computer module, and any combination of 6 I/O or network modules.

Expansion System:

A maximum system consists of a main rack and 3 expansion racks. Each rack can have up to 8 I/O modules. Expansion racks can also accept network modules. In addition to V-Series expansion racks, T2 Series expansion racks can also be connected to the main rack. A combination of V-Series and T2 Series expansion racks is possible.

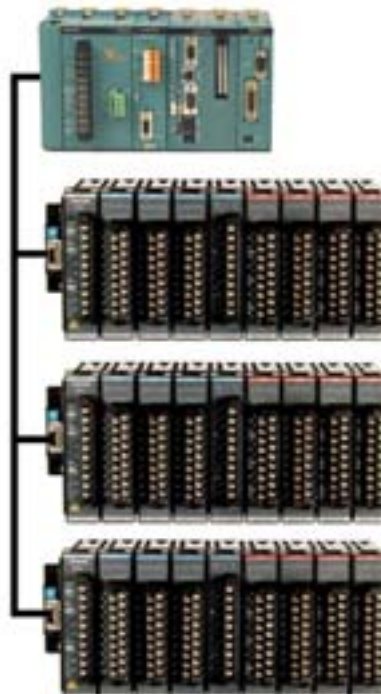
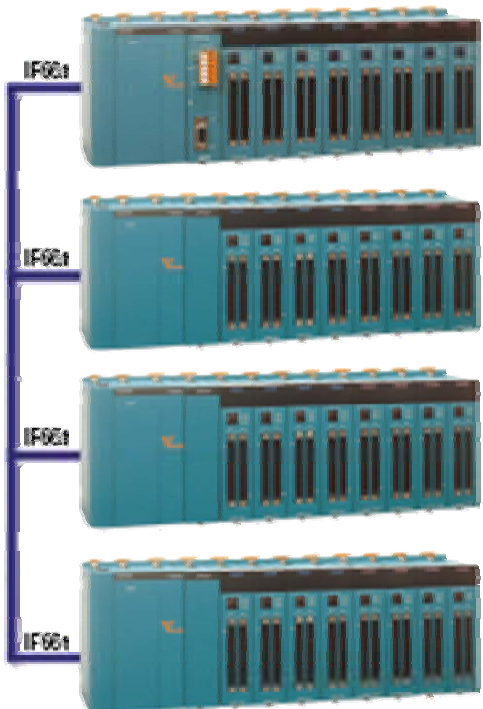

- ◆ A power supply module is necessary in each rack.
- ◆ Expansion cables are available as follows:
 - 30 cm,
 - 50 cm,
 - 70 cm,
 - 1.5 m
 - . Max length = 4.5 m.

SYSTEM COMPONENTS

A typical S2E/S2T system consists of a base rack with modules mounted on the rack. From left to right modules are: Expansion Interface, Power Supply, CPU, and I/O modules. If the rack supports the station bus, then a computer module or higher level network module can be mounted following the CPU module.

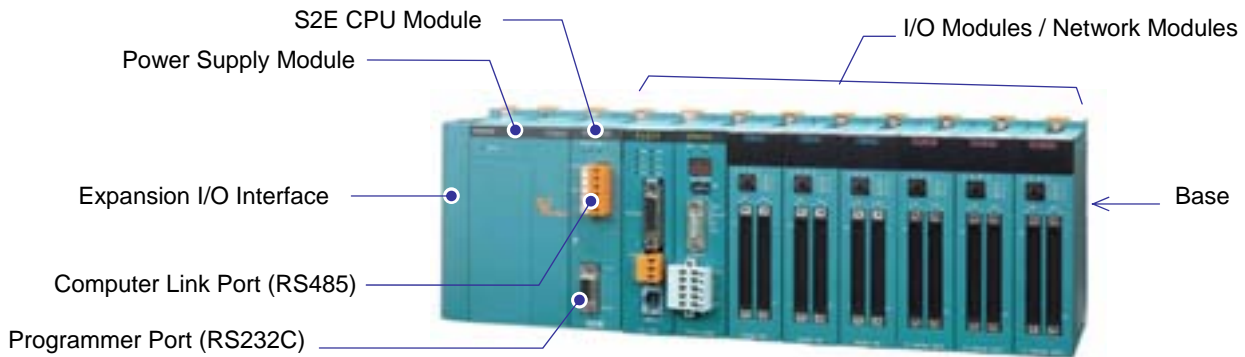

COMPUTER MODULE

It is no surprise that Toshiba Corporation, a company well known for rugged laptop computers, also has computer modules for its automation product line. The C2 module is a Pentium III air cooled, fan-less computer designed for harsh industrial and process environments. There are three models available:

Models:

Model No.	GC2PU37ES	GC2PU37GS	GC3PU37HS
CPU	Mobile Pentium P3, 500 Mhz Processor		
OS	Windows 2000 Pro	Windows 2000 Pro	Windows XP Pro
Cache Memory	Primary 32 Kb Secondary 256 Kb (CPU on die)		
RAM Memory	128 Mb	256 Mb	256 Mb
HDD or	30 Gb	30 Gb	30 Gb
Opt Flash Memory	2 Gb	2 Gb	2 Gb
IF: USB	1 Ch. (Type A USB 1.0)	1 Ch. (Type A USB 1.0)	1 Ch. (Type A USB 1.0)
Serial	1 Ch. RS232C, 9 pin	1 Ch. RS232C, 9 pin	1 Ch. RS232C, 9 pin
PS2	1 Ch. Mouse, 1 Ch. Keyboard		
LAN	1 Ch. Ethernet, 10 BaseT, 100 BaseTx, RJ45		
Display	1 Ch. RGB analog, 2 Mb RAM, 1600 x 1200, 65536 Colors		
PC Card	2 Slots, PCMCIA Type II		
RAS	CPU Failure Detection (WDT), Thermal Failure Detection, Auto Shutdown on Power Failure		
Note:	Requires S2T CPU and rack with station bus.		

Components:

All the components typically found on a computer are located on the front of the C2 computer module.

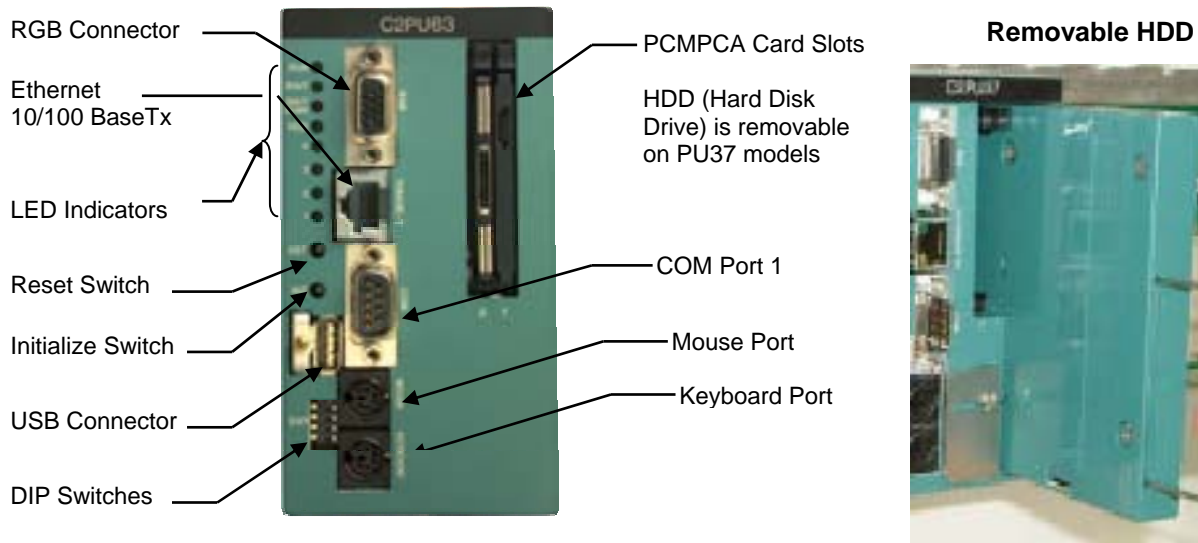

The hard disk in the C2 module (PU37) is removable. High amounts of data can be stored and easily removed from the computer at a more convenient time. It also permits easy replacement of the computer component most likely to experience an operational problem. Company MIS/IT departments can easily clone a hard disk so that a backup is available for critical applications.

Data Exchange:

Data is exchanged between the C2 module and the S2T module via the station bus. The S2T can collect data from the I/O modules and send it to the C2 module. The C2 module can perform any type of; complex calculations, diagnostic/statistical analysis, or data manipulation, then send the result back to the S2T module for action. The C2 module can also run any SCADA or HMI program that is often times run on an external PC.

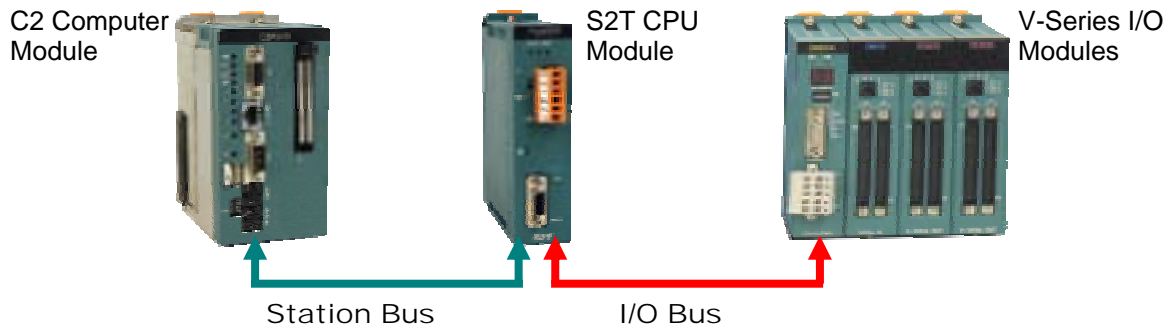

- Notes:
1. Contact Toshiba for applications requiring direct communications between the C2 module and the I/O modules (S2T CPU not required).
 2. Requires S2T CPU and rack with station bus.

C2 + S2T Application:

In the application possibility below, the S2T CPU controls operation of a tank farm and the C2 CPU controls the security system for the tank farm. In the event of either a process alarm or a security alarm, the C2 module sends notification out to the central facility or the on-duty foreman over the internet that an alarm has occurred. The notification can identify if the alarm is a process alarm or a security alarm.

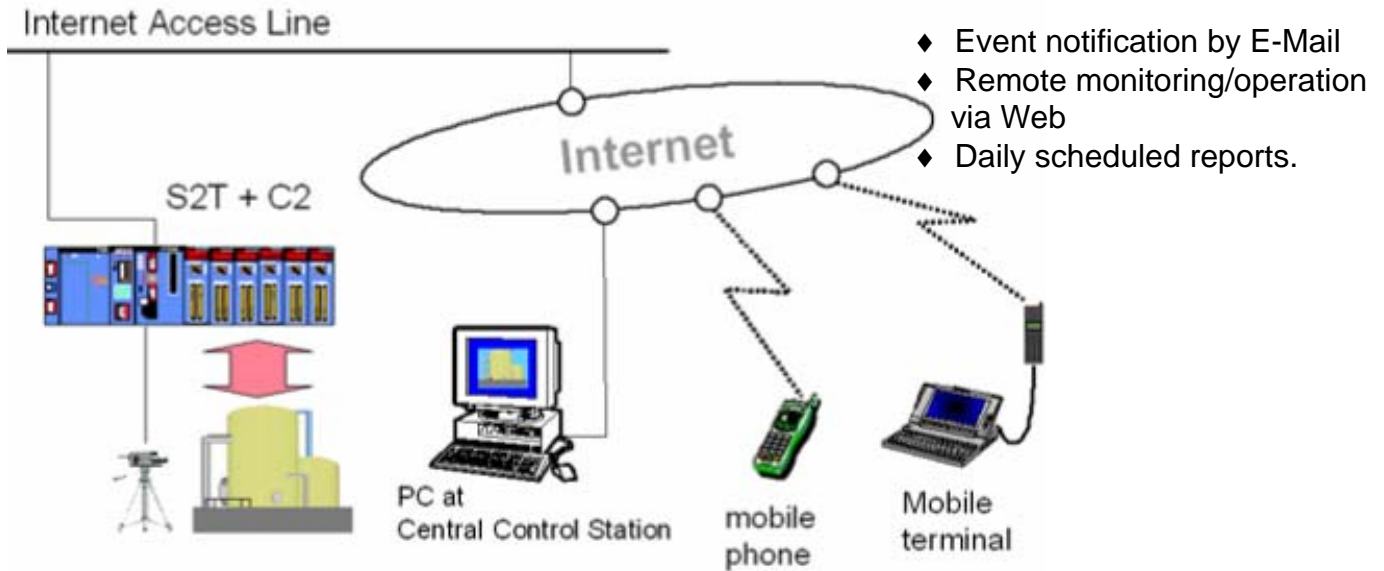

SPECIAL POWER SUPPLY MODULES

For critical PLC applications or applications using the C2 computer module, Toshiba offers two special power supply modules:

- ◆ The GPS691 has a special UPS interface.
- ◆ The GPS694 is a combination power supply and UPS.

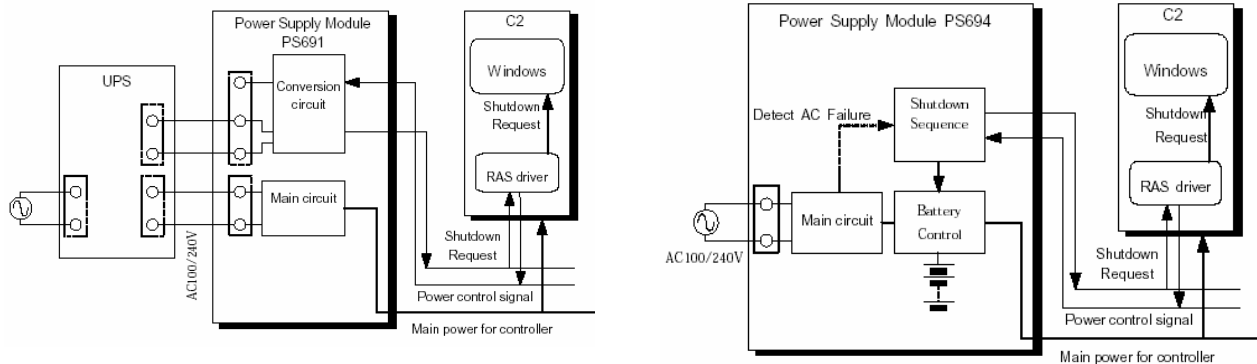

MS Windows must be shutdown in an orderly manner or data on the HDD can be corrupted, thus preventing a restart. When 120 Vac power is lost, the GPS691/GPS694 will signal the C2 computer module to begin an orderly shutdown of Windows. This is done without any input from a keypad or mouse. Power to the C2 module is maintained until Windows has shut-down.

NETWORKS

The S2E/S2T controllers can be part of a fully distributed networked control system. Levels range from Plant Information LAN to simple ASCII network.

Overview:

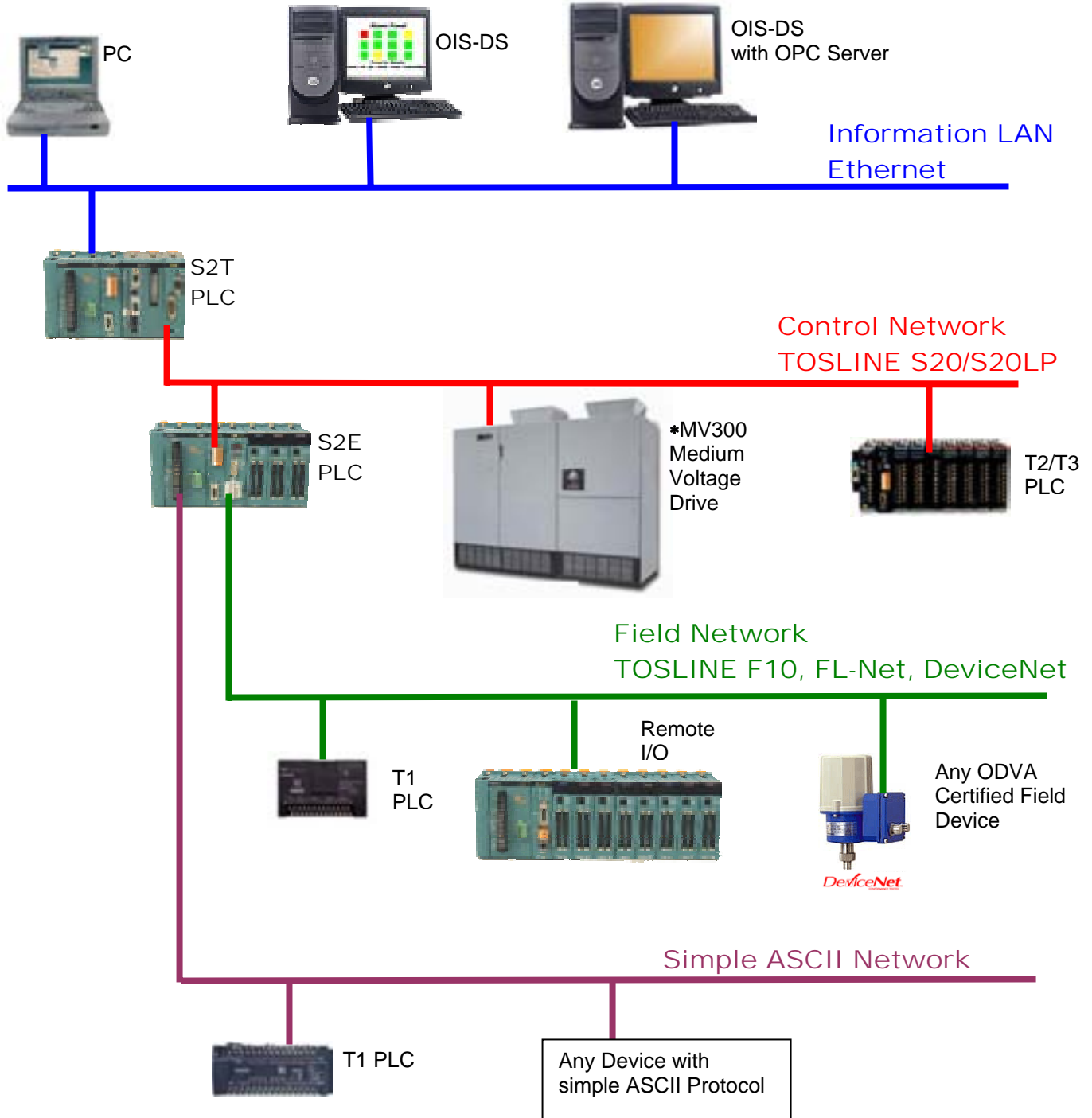

* An Active Star Coupler maybe necessary for connecting multiple ASDs (Adjustable Speed Drivers) on to a Tosline S20 network.

Ethernet:

Ethernet is used as an open industrial networking standard. The GEN651 allows the S2T to access other devices connected on an Ethernet network. Either 10 or 100 Mbps data rates can be selected. Cables, routers, switches, transceivers, converters, etc. are commonly available from 3rd party vendors.

Order Number	GEN651
Topology	Bus/Star
Protocol	Ethernet TCP/UDP
Transmission	Point-to-Point, Multicast, Broadcast
Transmission Speed	10 Mbps/100Mbps
Max No. of Stations	256
Max No. of Modules/Station	4
Max Distance	100m between stations/repeaters
Parameter Tool	EtherSetup_E Software
Note	

GEN651

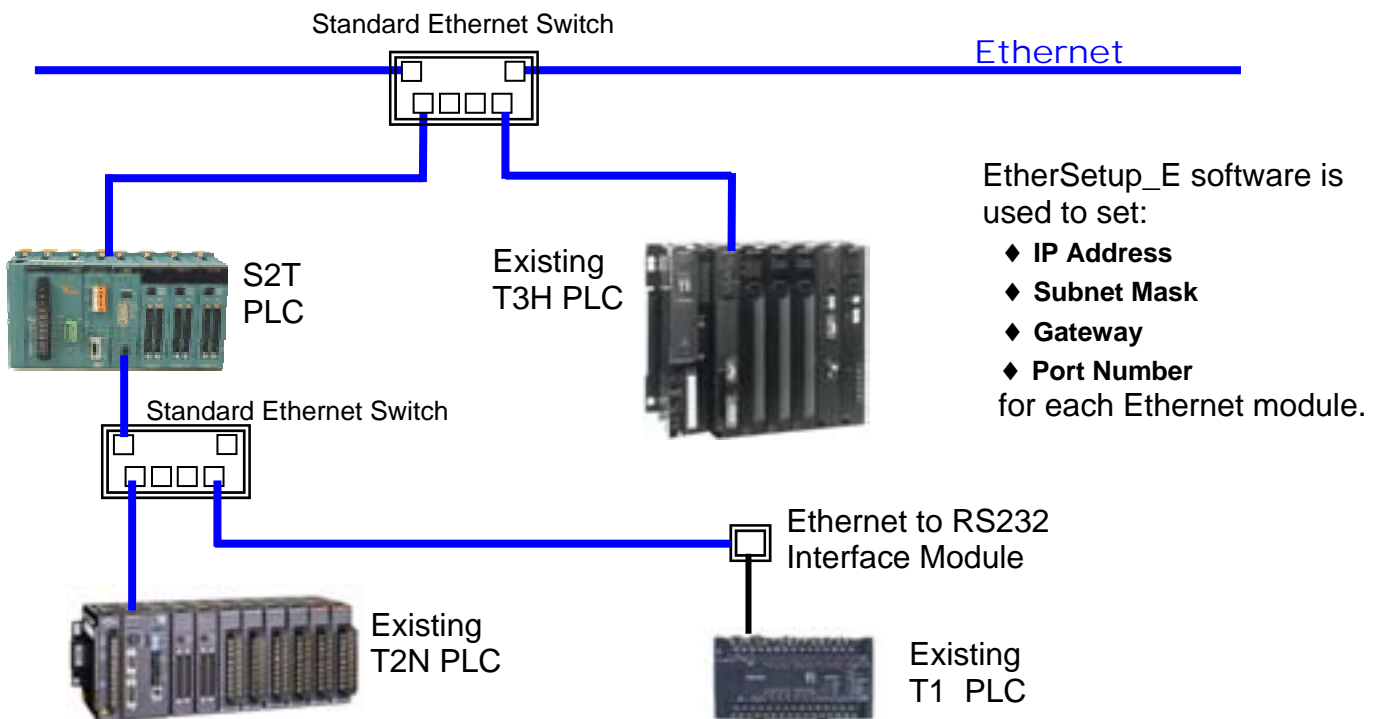

Tosline S20/S20LP:

Tosline S20/S20LP is an N-to-N high-speed data link network. Implicit token passing avoids the possibility of message collision. A Tosline S20/S20LP network is ideal for real-time control between PLCs or between PLCs and Toshiba ASDs.

Tosline-S20LP

The Tosline-S20LP is a high-reliability loop type fiber optic system. The double-loop configuration and the floating master function allow the Tosline-S20LP to continue data link operation even if a transmission cable is cut or a station drops out of the network.

Tosline S20

The Tosline-S20 is a bus type data link network. The transmission media can be either co-axial or fiber optic cable depending on the application requirement. These station modules can be mounted in any I/O slot, main, or expansion rack, of a S2E/S2T system.

Order Number	GSN627**S (S2T)	GSN626**S (S2T)	GSN625**S (S2T)
		GSN622**S (S2E)	GSN621**S (S2E)
Topology	Double Optic Loop	Optic Bus	Co-ax Bus
Transmission	Scan/Broadcast		
Transmission Speed	2 Mbps		
Max No. of Stations	64		
Max Distance	30 km total, 1 km between stations.	10 km total, 1 km between stations.	1 km total.
Scan Capacity	4096 words.	1024 words.	1024 words.
Scan Update Time	61.4 ms/4096 words.	25 ms/1024 words.	25 ms/1024 words.
Service	Scan Transmission & Message Transmission		
Parameter Tool	Tosline SLS Software.		
Connectable Devices	S2T, PCS, V1000.	S2E/S2T, PCS, ASD, MV300.	S2E/S2T, PCS, ASD,
Note	For Additional Details See TL-S20 & TL-S20LP User's Manuals		

SN622
SN626

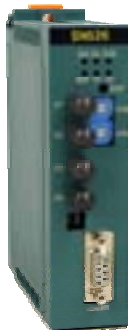

SN621
SN625



Remote Programming/Monitoring is possible through Tosline-S20/20LP

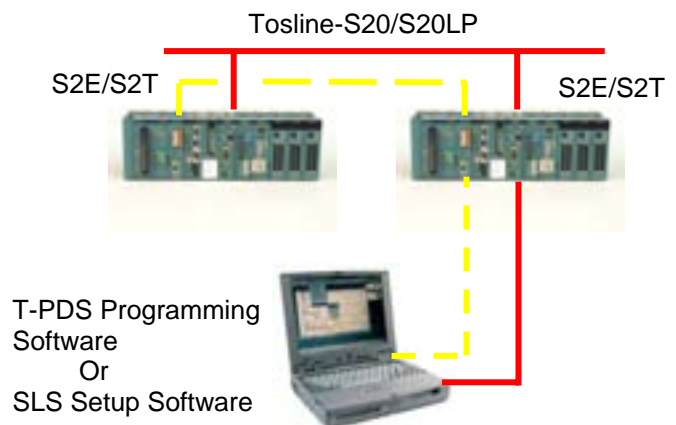

FL-Net:

FL-Net is a multi-vendor open network. Any equipment (PLC, NC, Robot Controller, etc.) that has an FL-Net certified communications module can communicate on FL-Net. FL-Net is a 10 Mbps deterministic Ethernet based network. Each station has a common memory which sends data to the respective memory location in the other stations. FL-Net uses standard Ethernet cable and network devices such as hubs, repeaters, etc). The GFL612 is a module that mounts in an S2E/S2T main or expansion rack. It allows the S2E/S2T to write data on the FL-Net and read data from the FL-Net. The GFL654 is a remote communications module that mounts in a V-Series rack with V-Series I/O. The GFL654 writes the status of its inputs on the FL-Net and sets its outputs according to data received from the FL-Net. It supports up to 32 V-Series I/O modules.

Order Number	GFL612**S	GFL654**S
Protocol	Ethernet UDP/IP	
Topology	Bus/Star	
Transmission	FL Control Network Ver. 2.0	
Transmission Speed	10 Mbps	
Max No. of Stations	254	
Max No. of Modules/Station	4	1
Max Distance	Per FL-Net Spec.	Per FL-Net Spec.
Scan Capacity	8 k words + 8 k bites	
Scan Update Time	50 ms or less	
Service	FL-Net Message Transmission	
Parameter Tool	S2E/S2T Program	Switches on Module
Conn. Devices	S2E/S2T, Any FL-Net certified device.	
Note	Not compatible with FL-Net Ver. 1.0	

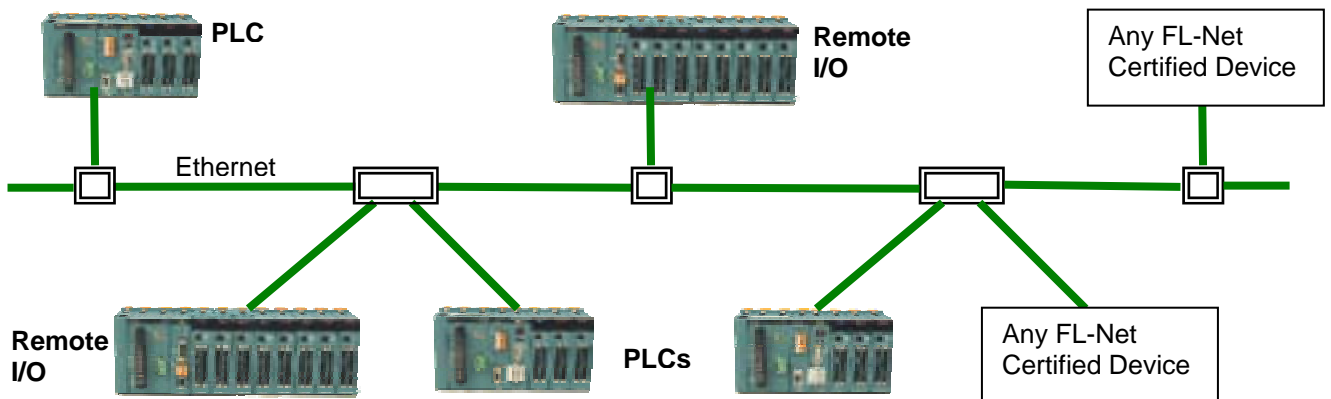

Tosline-F10:

Tosline- F10 is a field network suitable for small distributed I/O systems. It also allows data link between S2E/S2T and older T-Series/EX-Series PLCs. Tosline-F10 is extremely easy to setup and use compared to other field networks. There are two types of Tosline-F10 modules available for the S2E/S2T CPUs.

- ◆ GUN611 Master Station
- ◆ GUN612 Remote Station

Master Stn



Remote Stn



Model No.	GUN611**S & GUN612**S
Topology	Bus
Access Method	Poling/Selecting
Trans. Speed	750 Kbps/250 Kbps
Max. Trans Dist.	750 Kbps: 0.5 Km 250 Kbps: 1.0 Km.
Max No. of Stns	32
Comm Service	Scan Transmission
Capacity	32 Words
Update Time	7 ms/32 words (750 Kbps) 12 ms/32 words (250 Kbps).
Conn. Devices	S2E/S2t, T1/T2/T3 PLCs. Remote I/O Blks, ASD, etc.
Note:	For additional information see Tosline-F10 User's Manual

DeviceNet:

DeviceNet is an open field network. Many field devices (certified by ODVA) are available from other manufactures to connect to DeviceNet. The DN611A is a Toshiba DeviceNet scanner module for the S2E/S2T CPUs. The DN611A can read/write data to any other manufacturer's certified device; such as remote I/O blocks, manifolds valves, sensors, ASDs, etc.

GDN611A



Model No.	GDN611A*S		
Topology	Bus.		
Number of Slaves	63 max.		
Trans. Speed	125/250/500 Kbps.		
Media Access	CSMA/NBA		
Modulation	Base-band.		
Trans Dist. Thin	100 m		
Thick	125k	250k	500k
	500m	250m	100m
Max. Drop Length	6 m	6 m	6 m
Total Drop Length	156m	78m	39m
Function	Bit Strop, Poll,		
Number of DN611	Limited by PS Capacity.		
Note:	For Additional Information see GDN611 User's Manual.		

ASCII Networks

The S2E & S2T have two ports that can be used for ASCII communications, the RS232 programming port and the RS485 serial port. Both ports can function in the Computer Link Mode. The RS485 serial port can also function in the Free ASCII mode.

Port.	Program RS232	Serial RS485
Trans. Method	Half-duplex	Half-duplex
Trans. Speed	9600 Bps	9600/19,200 Bps
Framing	Start Bit: 1 Data Bits: 8 Parity: Odd/None Stop Bit: 1	Start Bit: 1 Data Bits: 7/8 Parity: Odd/Even/None Stop Bit: 1/2
Protocol	Computer Link Programmer	Computer Link Free ASCII Programmer

Programmer Port—Computer Link Mode



Operator Interface Station (like the OIS60) connected directly to controller. This leaves the RS485 port open for remote connection by T-PDS programming software, SCADA software or other OISs'.

Serial Port—Computer Link Mode

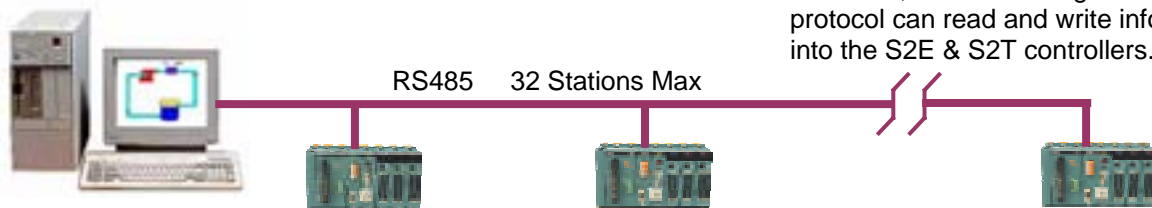

Any higher level computer, cell controller, or DCS having T-Series protocol can read and write information into the S2E & S2T controllers.

Serial Port—Free ASCII Mode

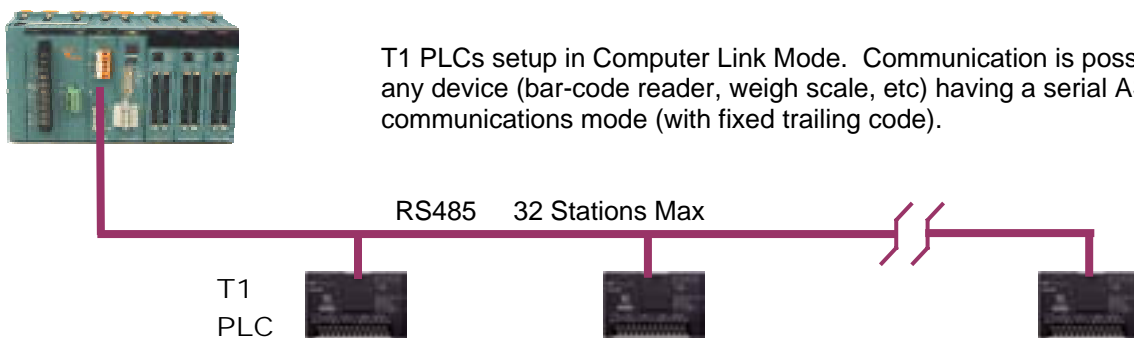

T1 PLCs setup in Computer Link Mode. Communication is possible to any device (bar-code reader, weigh scale, etc) having a serial ASCII communications mode (with fixed trailing code).

PROGRAMMING SOFTWARE

T-PDS (Toshiba-Program Development Software) is used for entering programs into the S2E & S2T CPUs. T-PDS is a software that runs on any Toshiba Notebook Computer or other IBM-PC compatible personal computer with MS Windows 95 or higher. T-PDS supports on-line & off-line programming, debugging, and program documentation for all T-Series programmable controllers. T-PDS has:



- ◆ A full-featured program editor that includes cut & paste search & replace, insert, delete, etc.
- ◆ Group programming and block merger.
- ◆ Load, save, and compare programs between disk file and CPU.
- ◆ Monitor power flow status of on-line ladder program and register values.
- ◆ Sample trace for determining time relationships of events.
- ◆ /O Force ON & OFF from keyboard.
- ◆ Print map options such as register values, register/device usage, full cross-reference, etc.
- ◆ Built-modem initialize and dial.

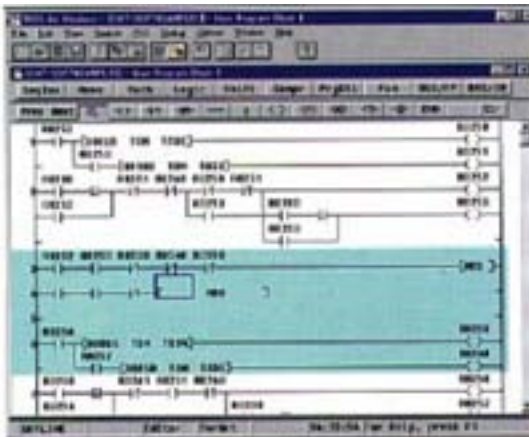

Program edit screen

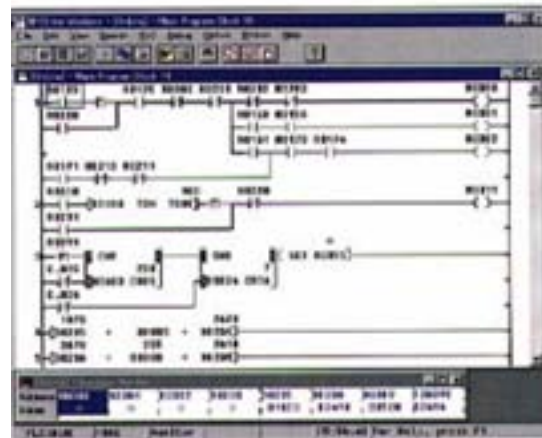

Program execution monitor (Ladder)

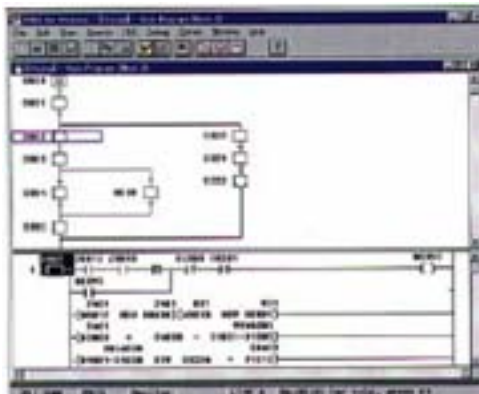

Program execution monitor (SFC)

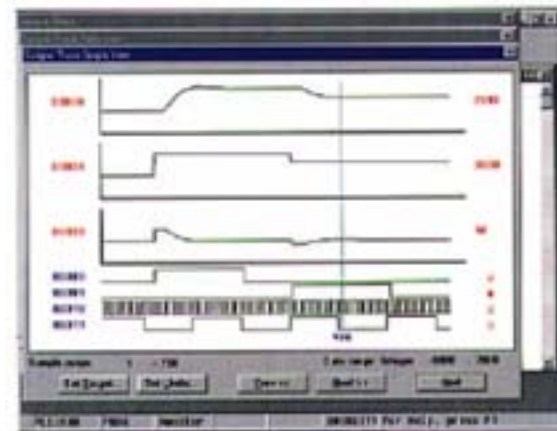

Sampling trace screen

GENERAL SPECIFICATIONS

Item	Specification
Operation temperature	0 to 55°C
Storage temperature	-20 to 70°C
Humidity	5 to 95%RH (no condensation)
Dust	10mg/m ³ or less
Atmosphere	No corrosive gas, no flammable gas
Vibration immunity	IEC61131-2 (10 to 150Hz, 9.8m/s ²)
Shock immunity	IEC61131-2 (150m/s ²)
Noise immunity	Power impulse: 1500Vp-p 1μs ESD: 8kV EMC directive
Insulation resistance	50MΩ or more (between external and internal circuits)
Withstand voltage	1500Vac for 1 minute
Grounding	100Ω or less (type D grounding)
Cooling	Natural air cooling

FUNCTIONAL SPECIFICATIONS

Item	Specification	
Control Method	Stored program cyclic scan method	
Processor	Overall control: 32-bit microprocessor Instruction execution: Special designed language processor (LP)	
Station Bus	S2T only.	
I/O Method	Batch I/O (refresh with main task), direct I/O, or combination	
Number of I/O Points	1024 points (when 32 points I/O used) 2048 points (when 64 points I/O used) Local I/O memory: 8192 bits/512 words (1 word = 16 bits)	
Application program	Programming Language	Ladder diagram (relay symbol + function block) Sequential Function Chart (SFC),
	Program Capacity	Steps: S2E=32K, S2T=32K (PU662T), S2T=64K (PU672T). Includes comments.
	Memory	Main memory: SRAM (battery back-up) Auxiliary memory: Flash memory (for program backup).
	Instruction Set	Basic ladder instructions: 24 types Function instructions: 206 types <ul style="list-style-type: none"> • Sequence (contact, coil, timer, counter, etc.) • Data transfer (single word / double word, register table) • Arithmetic (single word / double word, binary / BCD, signed / unsigned, floating-point) • Logic operation (single word/double word, register table, bit table) • Compare (single word / double word, signed / unsigned, floating-point) • Program control (jump, For-Next, subroutine, SFC, etc.) • Functions (limit, trigonometric, square root, integral, PID, function generator, etc.) • Conversion (ASCII, BCD, 7-Seg, double word integer / floating-point real) Others
	Execution Speed	S2E: 0.11μs / contact, 0.22μs / coil, 0.65μs / transfer, 1.08μs / addition, 17.3μs / floating-point mpl. S2T: 0.09μs / contact, 0.18μs / coil, 0.54μs / transfer, 0.90μs / addition, 12.1μs / floating-point mpl
Scan System	Floating scan or constant scan (constant: 10 to 200ms, 10ms units)	
Multi-Tasking	1 Main program 4 Sub-program (1 initial task fixed) 1 Timer interrupt (interval: 1 to 1000ms, 1ms units) 8 I/O interrupt (task switch 500μs or less) 256 Subroutines	

User data	I/O Relay/Register	8192 points / 512 words (X/Y or XW/YW: batch I/O, I/O or IW/OW: direct I/O)	
	Auxiliary Relay/Register	16000 points / 1000 words (R/RW)	
	Special Relay/Register	4096 points / 256 words (S/SW)	
	Timer Relay/Register	1000 points (T./T) (10ms timers or 100ms timers: user setting, default: 64 10ms timers)	
	Counter Relay/Register	512 points (C./C)	
	Data Register	8192 words (D)	
	Link Relay/Register	16000 points / 2048 words (Z/W) for TOSLINE-S20 (leading 1000 words: bit access possible)	
	Link Relay/Register	4096 points / 256 words (L/LW) for TOSLINE-F10	
	File Register	32768 words (F), 512k additional for PU672T	
	Index Register	3 words (I, J, K)	
	Retentive Memory	User specified range for RW, T, C, D, and whole F registers	
Real-time Clock/Calendar		Year, month, day, of the week, hour, minute, second (battery back-up)	
Comm Ports	Computer Link Port	Interface	RS485 (4-wire)
		Bit rate	300, 600, 1200, 2400, 4800, 9600, 19200 bps
		Protocol	Computer link mode: T-series computer link protocol (ASCII/binary) Free ASCII mode: non-procedure (desired message, max. 512 bytes)
	Programmer Port	Interface	RS232C
		Bit rate	9600 bps (fixed)
		Protocol	T-series computer link protocol (ASCII/binary) (available ASCII command: ST, DR, DW)
RAS	Self-Diagnosis	Power interrupt check, battery voltage check, I/O bus check, I/O registration check, I/O response, I/O parity, watchdog timer, illegal instruction, LP check, others	
	Monitoring	Event history record, scan time measurement, constant scan delay, others	
	Debug/Maintenance	On-line trace monitor, force function, sampling trace, status latch, others	

I/O MODULE SPECIFICATIONS

Digital Inputs:

Item	DI632D	DI653	IN653	IN663
Module type	DC input, sink/source		AC input	
Input voltage	12 to 24Vdc/ac, +10/-15%	100 to 110Vdc, +10/-15%	100 to 120Vac, +10/15% (50/60Hz)	200 to 240Vac, +10/15%(50/60Hz)
Min. ON voltage	9.6V	84V	80Vac	160Vac
Max. OFF voltage	4.3V	22V	30Vac	60Vac
Input current	8mA (at 24Vdc)	2.3mA (at 100Vdc)	7mA (at 100Vac)	6mA (at 200Vac)
Input points	8 points (isolated)	16 points (8/common)	16points (16/common)	16points (16/common)
ON delay time	10ms or less (DC) 20ms or less (AC)	10ms or less	20ms or less	20ms or less
OFF delay time	10ms or less (DC) 15ms or less (AC)	10ms or less	15ms or less	15ms or less
Wire connection	Terminal block	Terminal block	Terminal block	Terminal block
Internal 5V power consumption	100mA	100mA	15mA	15mA

Digital Outputs:

Item	DO633	DO634	DO635	DO633P
Module type	DC output, sink			DC output, source
Output voltage	5 to 24Vdc, +10/-5%	5 to 24Vdc, ±10%	5 to 24Vdc, ±10%	12 to 24Vdc, +10/-5%
Load current	1A/point (12/24V) 0.3A/point (5V) 1.2A/4 points	0.1A/point (12/24V) 0.05A/point (5V)	0.1A/point (12/24V) 0.05A/point (5V)	1A/point (12/24V) 1.2A/4 points
Output points	16 points (16/common)	32 points (8/common)	64 points (8/common)	16 points (16/common)
ON delay time	1ms or less	1ms or less	1ms or less	1ms or less
OFF delay time	1ms or less	1ms or less	1ms or less	1ms or less
Leakage current	0.1mA or less (24Vdc)	0.1mA or less (24Vdc)	0.1mA or less (24Vdc)	0.1mA or less (24Vdc)
Wire connection	Terminal block	Connector	Connector	Terminal block
Internal 5V power consumption	60mA	150mA	250mA	60mA

Item	RO663	RO662S	AC663
Module type	Relay contact output, NO contact		AC output
Output voltage	24Vdc, +20% (max) 240Vac, +10% (max)	24Vdc, +20% (max) 240Vac, +10% (max)	100 to 240Vac, +10/-15% (50/60Hz)
Load current	2A/point (resistive load) 8A/common	2A/point (resistive load)	0.5A/point 0.6A/2 points
Output points	16 points (8/common)	8 points (isolated)	12 points (4/common)
ON delay time	10ms or less	10ms or less	1ms or less
OFF delay time	15ms or less	15ms or less	1/2 cycle + 1ms or less
Leakage current	None	None	1.2mA or less (at 100Vac) 3mA or less (at 240Vac)
Wire connection	Terminal block	Terminal block	Terminal block
Internal 5V power consumption	80mA	40mA	300mA

Analog Inputs:

Item	AD624L	AD634L	AD624	AD674
Input signal	1 to 5V, 4 to 20mA	0 to 10V	1 to 5V, 4 to 20mA	±10V
Input impedance	Voltage: 500kΩ or more Current: 250Ω	500kΩ or more	Voltage: 1MΩ or more Current: 250Ω	1MΩ or more
Input channels	4 channels	4 channels	4 channels	4 channels
Resolution	8 bit (0 to 250)	8 bit (0 to 250)	12 bit (0 to 4000)	12 bit (-2000 to 2000)
Conversion cycle	1ms/4 channels	1ms/4 channels	2ms/4 channels	2ms/4 channels
Overall accuracy	±1%FS (0 to 55°C)	±1%FS (0 to 55°C)	±0.5%FS (25°C) ±1%FS (0 to 55°C)	±0.5%FS (25°C) ±1%FS (0 to 55°C)
Internal 5V power consumption	50mA	50mA	50mA	50mA

Item	AD628S	AD638S	AD668
Input signal	0 to 5V, 0 to 20mA	±10V	±5V, ±10V, 0 to 5V, 0 to 10V, 1 to 5V, 0 to 20mA, 4 to 20mA
Input impedance	Voltage: 500kΩ or more Current: 250Ω	500kΩ or more	Voltage: 1MΩ or more Current: 250Ω
Input channels	8 channels (isolated)	8 channels (isolated)	8 channels
Resolution	12 bit (0 to 4000)	12 bit (-2000 to 2000)	16 bit (-32000 to 32000) (FS: ±10V)
Conversion cycle	2ms/8 channels	2ms/8 channels	1ms/channel (8ms/8 channels)
Overall accuracy	±0.2%FS (25°C) ±1%FS (0 to 55°C)	±0.2%FS (25°C) ±1%FS (0 to 55°C)	±0.2%FS (25°C) ±0.5%FS (0 to 55°C)
Internal 5V power consumption	600mA	600mA	300mA

Temperature Inputs:

Item	TC618		RT614
Input signal	Thermocouple K, J, E	±100mV	Pt100 (3-wire)
Temperature input range	K: -200 to 1200°C J: -200 to 800°C E: -200 to 600°C	-	-50 to 270°C
Input channels	7 channels (1ch for CJC)	8 channels	4 channels
Resolution	16 bit (0.05°C/count)	16 bit (-32000 to 32000)	12 bit (0.1°C/count)
Conversion cycle	1ms/channel (8ms/8 channel) (averaging available)		200ms/4 channels
Overall accuracy	±0.2%FS (25°C), ±0.5%FS (0 to 55°C)		±0.3%FS (25°C)
Internal 5V power consumption	300mA		500mA

Pulse Inputs:

Item	PI632	PI672
Input channels	2 channels (phase A, B, M)	2 channels (phase A, B, M)
Input voltage	5/12/24V, ±5%	Conforms to RS422
Input current	15.5mA (5V), 15mA (12V), 12.5mA (24V)	
Input pulse rate	Max. 100kpps (other than quadrature) Max. 50kpps (quadrature)	Max. 100kpps (other than quadrature) Max. 50kpps (quadrature)
Counting rate	Max. 200k count/sec	Max. 200k count/sec
Count value	24-bit binary (0 to 16777215)	24-bit binary (0 to 16777215)
Counter operation mode	Quadrature bi-pulse counter (90° phase shift), up/down counter (phase A = up / phase B = down), auto-reset universal counter, speed counter, programmable interval timer, gate ON timer	
Interrupt function	Interrupt generation at count match with preset (main unit only)	
Internal 5V power consumption	500mA	650mA

Analog Outputs:

Item	DA622L	DA622	DA672
Output signal	1 to 5V, 4to 20mA	1 to 5V, 4to 20mA	±10V
Load impedance	Voltage: 5kΩ or more Current: 600Ω or less	Voltage: 5kΩ or more Current: 600Ω or less	5kΩ or more
Output channels	2 channels	2 channels	2 channels
Resolution	8 bit (0 to 250)	12 bit (0 to 4000)	12 bit (-2000 to 2000)
Conversion cycle	1ms/2 channels	1ms/2 channels	1ms/2 channels
Overall accuracy	±1%FS (0 to 55°C)	±0.5%FS (25°C) ±1%FS (0 to 55°C)	±0.5%FS (25°C) ±1%FS (0 to 55°C)
Internal 5V power consumption	70mA	170mA	170mA

Item	DA664	DA624S
Output signal	±5V, ±10V, 0 to 5V, 0 to 10V, 1 to 5V, 0 to 20mA, 4 to 20mA	0 to 20mA
Load impedance	Voltage: 1kΩ or more, current: 600Ω or less	550Ω or less
Output channels	4 channels	4 channels (isolated)
Resolution	16 bit (-32000 to 32000) (FS: ±10V)	16 bit (0 to 64000)
Conversion cycle	1ms/channel (4ms/4 channels)	1ms/4 channel or less
Overall accuracy	±0.2%FS (25°C) ±0.5%FS (0 to 55°C)	±0.2%FS (25°C) ±0.5%FS (0 to 55°C)
Output at PLC error	-	Output hold or reset (selectable)
Internal 5V power consumption	230mA	220mA

Change Detect DC Input

Item	CD633
Input voltage	12 to 24Vdc, +10/-15%
Min. ON voltage	9.6V
Max. OFF voltage	3.6V
Input current	7mA (at 24Vdc)
Input points	16 points (16 points/ common)
ON delay time	1ms or less
OFF delay time	1ms or less
Interrupt function	Interrupt generation at input signal state changing* (main unit only) * signal state changing: rising / falling / both (user setting)
Internal 5V power consumption	200mA

Communication Interface

Item	CF611
Interface	RS232C, 1 port
Transmission mode	Full duplex
Synchronizing	Start-stop method (asynchronous)
Protocol	Non-procedure (trailing code detection)
Bit rate	300, 600, 1200, 2400, 4800, 9600, 19200 bps
Code	ASCII (7 or 8 bits)
Message length	Max. 320 byte
Connectable device	Computer, bar-code reader, display device, sensor, printer, or other serial ASCII devices
Signal connection	D-Sub 9-pin connector (female)
Internal 5V power consumption	550mA

Position Control Outputs

Item	MC612	MC614
Number of axis	2 axis	4 axis
Control method	Pulse train output	Pulse train output
Axis control	Each axis independent, 2 axis linear interpolation	Each axis independent, 2 axis linear interpolation, 2 axis circular interpolation
Control units	Pulse, mm, inch, degree, etc.	Pulse
Positioning range	±9,999,999 (control units)	-134,217,727 to +134,217,726
Pulse output speed	Max. 200kpps	Max. 1.3Mpps
Pulse output method	CW/CCW or pulse + direction	CW/CCW or pulse + direction
Pulse output signal	5 to 24Vdc (50mA), RS422	RS422
Acc/dec system	Automatic trapezoidal	Automatic trapezoidal / automatic S curve
Operation mode	Zero return, Jog, fix feed, direct positioning, point No operation, automatic stepping, jog/position switch, interrupt positioning	Zero return, Jog, direct positioning, point No operation, automatic stepping, pulsar input operation
Other functions	Electric gear, over ride, position change, back-rash compensation, teaching, feed-back pulse input (for monitoring)	Over ride, position change, back-rash compensation, teaching
Internal 5V power consumption	700mA	700mA

PART (Order) NUMBERS

Basic Components:

Name	Description	Type	Part Number
S2E CPU Module	32K steps, built-in RS485 port	PU612E	GPU612E*S
S2T CPU Modules	32K steps, built-in RS485 port	PU662T	GPU662T*S
	64K steps, built-in RS485 port, 1 Mb Memory	PU672T	GPU672T*S
C2 Computer Modules	P-III, 500 Mhz, 128 Mb RAM, 30 Gb HDD, Windows 2000 Pro	C2PU37	GC2PU37ES
	P-III, 500 Mhz, 256 Mb RAM, 30 Gb HDD, Windows 2000 Pro	C2PU37	GC2PU37GS
	P-III, 500 Mhz, 256 Mb RAM, 30 Gb HDD, Windows XP Pro	C2PU37	GC2PU37HS
Power Supply Modules	24Vdc Input	PS632	GPS632**S
	100 to 110 Vdc Input	PS652	GPS652**S
	100 to 240 Vac, w/UPS Interface Connection	PS691	GPS691**S
	100 to 240 Vac Input	PS693	GPU693**S
Base (main/expansion common)	100 to 240 Vac, w/Battery for Computer Module Shutdown	PS694	GPS694**S
	Base Rack for S2T/S2, 4 Station Bus Slots, no I/O slots. Not for S2E.	BU643D	GBU643D*S
	Base Rack for S2T/S2, 9 Slots (Up to 5 station bus slots). Not for S2E.	BU643E	GBU648E*S
	Base Rack for S2E, 3 I/O Slots/ Expansion Rack for S2T/S2, 4 I/O Slots.	BU664	GBU664**S
Expansion I/O interface	Base Rack for S2E, 5 I/O Slots/ Expansion Rack for S2T/S2, 6 I/O Slots.	BU666	GBU666**S
	Base Rack for S2E, 7 I/O Slots/ Expansion Rack for S2T/S2, 8 I/O Slots.	BU668	GBU668**S
	Parallel I/O bus 1 line (main/expansion common)	IF661	GIF661**S

I/O Modules:

Name	Description	Type	Part Number
DC Input	8 points (isolated), 12-24Vdc/ac input	DI632D	GDI632D*S
	16 points, 12-24Vdc/ac input	DI633	GDI633**S
	32 points, 24Vdc input	DI634	GDI634**S
	64 points, 24Vdc input	DI635	GDI635**S
	64 points, 24Vdc input (high-speed)	DI635H	GDI635H*S
AC Input	16 points, 100-110Vdc input	DI653	GDI653**S
	16 points, 100-120Vac input	IN653	GIN653**S
DC Output	16 points, 200-240Vac input	IN663	GIN663**S
	16 points, 24Vdc output, 1A/point	DO633	GDO633**S
AC Output	16 points, 24Vdc output, 1A/point (current source)	DO633P	GDO633P*S
	32 points, 24Vdc output, 0.1A/point	DO634	GDO634**S
	64 points, 24Vdc output, 0.1A/point	DO635	GDO635**S
Relay Contact Output	12 points, 100-240Vac output, 0.5A/point	AC663	GAC663**S
Analog Input	16 points, 240Vac/24Vdc output, 2A/point	RO663	GRO663**S
	8 points (isolated), 240Vac/24Vdc output, 2A/point	RO662S	GRO662S*S
	4 channels, 1-5V / 4-20mA, 8 bit	AD624L	GAD624L*S
	4 channels, 0-10V, 8 bit	AD634L	GAD634L*S
	4 channels, 1-5V / 4-20mA, 12 bit	AD624	GAD624**S
	4 channels, $\pm 10V$, 12 bit	AD674	GAD674**S
	8 channels, 0-5V / 1-5V / $\pm 5V$ / $\pm 10V$ / 0-20mA / 4-20mA, 16 bit	AD668	GAD668**S
	8 channels (isolated), 0-5V / 0-20mA, 12 bit	AD628S	GAD628S*S
RTD Input	8 channels (isolated), $\pm 10V$, 12 bit	AD638S	GAD638S*S
Thermocouple Input	4 channels, Pt100 input, 12 bit	RT614	GRT614**S
Analog Output	8 channels, K / J / E / $\pm 100mV$, 16 bit	TC618	GTC618**S
	2 channels, 1-5V / 4-20mA, 8 bit	DA622L	GDA622L*S
	2 channels, 1-5V / 4-20mA, 12 bit	DA622	GDA622**S
	2 channels, $\pm 10V$, 12 bit	DA672	GDA672**S
	4 channels, 0-5V / 1-5V / $\pm 5V$ / $\pm 10V$ / 0-20mA / 4-20mA, 16 bit	DA664	GDA664**S
Pulse Input	4 channels (isolated), 0-20mA, 16 bit (output hold available)	DA624S	GDA624S*S
Change Detect DC Input	2 channels, 100kpps, 5/12/24Vdc (interrupt generation)	PI632	GPI632**S
	2 channels, 100kpps, RS422 (interrupt generation)	PI672	GPI672**S
Position Control	16 points, 12-24Vdc input (interrupt generation)	CD632	GCD632**S
Communication Interface	2 axis, pulse output, 200kpps, independent / linear interpolation	MC612	GMC612**S
	4 axis, pulse output, 1.3Mpps, independent / linear / circular interpolation	MC614	GMC614**S
	RS232C 1 port, ASCII non-procedure	CF611	GCF611**S

Network Modules:

Name	Description	Type	Part Number
Ethernet	Ethernet 10/100 BaseT, for S2T CPU only.	EN651A	GEN651A*S
FL-Net	FL-Net controller station (Ver.2.0)	FL612	GFL612**S
	FL-Net remote I/O station (Ver.2.0)	FL654	GFL654**S
TOSLINE-S20	TOSLINE-S20 co-axial bus (S2E)	SN621	GSN621**S
	TOSLINE-S20 co-axial bus (S2T)	SN625	GSN625**S
	TOSLINE-S20 optical bus (S2E)	SN622	GSN622**S
	TOSLINE-S20LP (loop) optical bus (S2T)	SN626	GSN626**S
	TOSLINE-S20DLP (double loop) optical bus (S2T)	SN627	GSN627**S
DeviceNet	Scanner module	DN611A	GDN611A*S
TOSLINE-F10	Master station	UN611	GUN611**S
	Remote station	UN612	GUN612**S

Cables:

Name	Description	Type	Part Number
I/O Expansion Cables	0.3m length	CS6R3	GCS6R3*CS
	0.5m length	CS6R5	GCS6R5*CS
	0.7m length	CS6R7	GCS6R7*CS
	1.2m length	CS6*1	GCS6*1*CS
T-PDS Connection Cable	5m length	CJ905	TCJ905*CS

Support Software:

Name	Description	Type	Part Number
Programming Tool	Windows95/98/Me/NT/2000/XP (English), CD-ROM version	TPDS32	TMW3CE2SS
S20 Configuration Tool	Windows95/98/Me/NT/2000/XP (English)	S-LS	SMW23E*SS
DeviceNet Wizard	DeviceNet Wizard for TOSHIBA (English)	-	TDW33E2SS
DDE Server	Windows98/Me/NT/2000 (English)	T-PSV	TPV33E2SS

Miscellaneous:

Name	Description	Type	Part Number
Vacant Slot Cover	Blank module for vacant slot	SP600	GSP600**S
Battery	Spare lithium battery	BT611	GBT611*AS

Note: Type Number is often times the number found on a module. However the Part Number is necessary for ordering a new/replacement module.

EXTERNAL DIMENSIONS

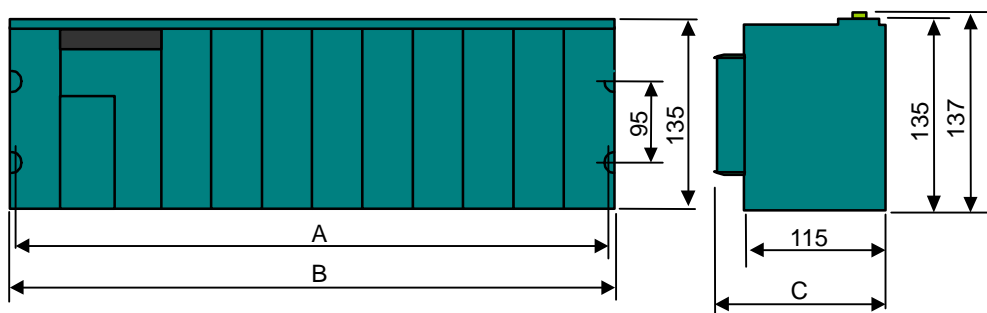

	BU668/BU648E	BU666	BU664/BU643D
A	402.5	295.5	224.5
B	417	309.5	238.5

	Terminal block	Connector
C	143	169

Units = mm

QUALITY

Toshiba Corporation is a vertically integrated manufacturing company. Semiconductors are the building blocks of all electrical and electronic equipment and Toshiba is one of the leaders in semiconductor fabrication. Toshiba's integration continues through printed circuit board assembly and testing to complete finished products (notebook computer, television, adjustable speed drive, X-ray machine, PLC, etc.)

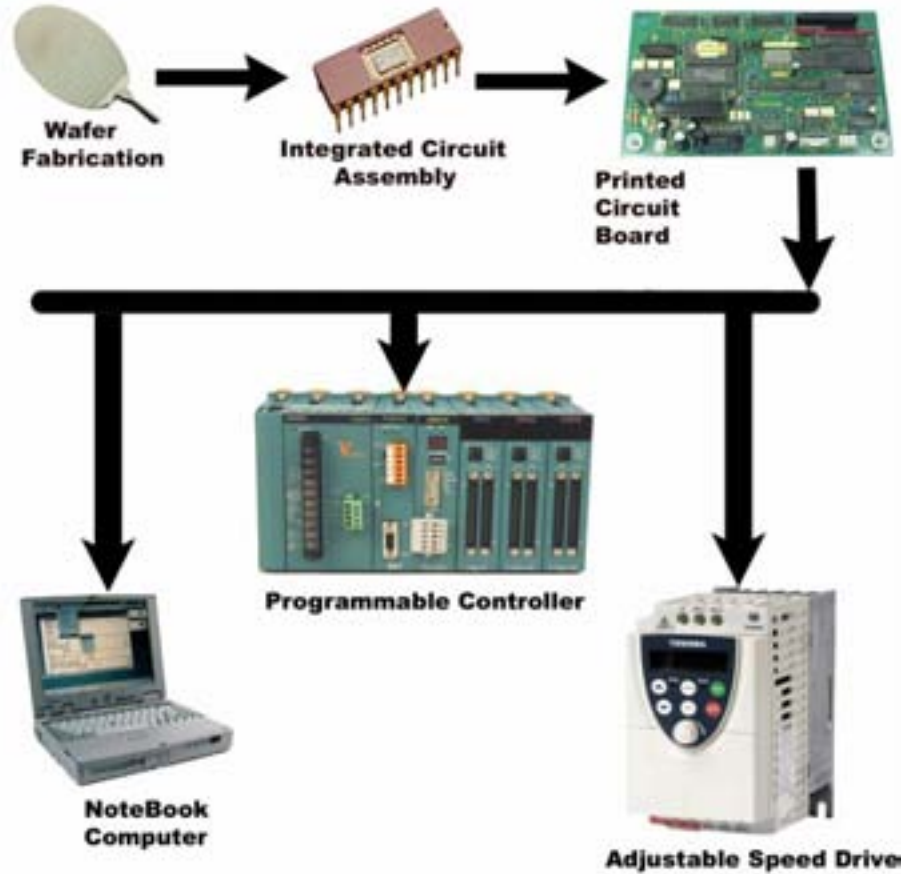

Toshiba Corporation's quality management system in design, development and manufacturing insure that all Toshiba products meet or exceed the requirements of Quality Management Standard ISO9001.

OTHER TOSHIBA GROUP INDUSTRIAL PRODUCTS

TOSHIBA

TOSHIBA INTERNATIONAL CORPORATION



After choosing the V-Series PLC, please consider other Toshiba Corporation's and Toshiba International Corporation's other high quality industrial products. All of these products are designed for rugged industrial applications and can provide a worry free installation.

ADJUSTABLE SPEED DRIVES MOTORS CONTROLS UPS INSTRUMENTATION PLC

TOSHIBA

Available Through:

TOSHIBA INTERNATIONAL CORPORATION

INDUSTRIAL DIVISION

13131 West Little York Road, Houston, Texas 77041

Tel 713/466-0277 Fax 713/466-8773

US 800/231-1412 Canada 800/872-2192 Mexico 01/800/527-1204

www.tic.toshiba.com